

F. E. HAHN.  
Work-Holding Devices.

No. 146,064.

Patented Dec. 30, 1873.

FIG. 1.

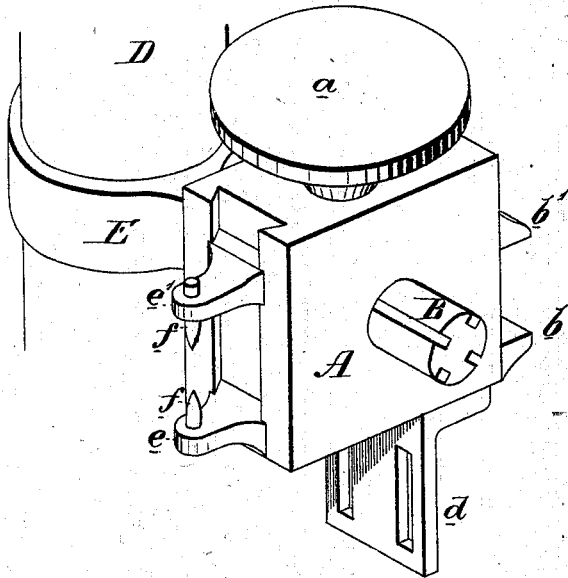
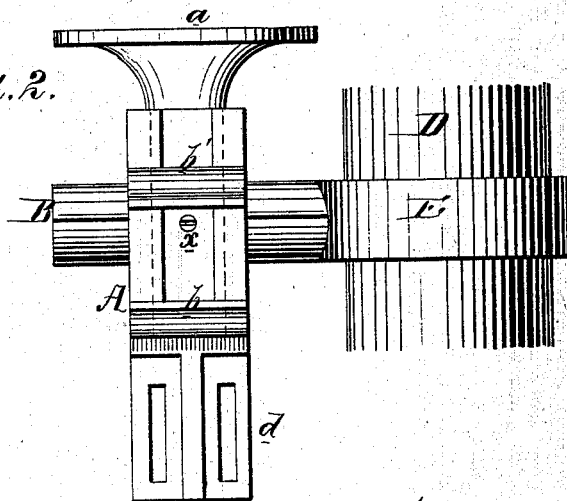

FIG. 2.



Witnesses, John K. Rupertus  
Thomas McAlvain

Francis E. Hahn  
By his Atty,  
Howes and Son

# UNITED STATES PATENT OFFICE.

FRANCIS E. HAHN, OF PHILADELPHIA, PENNSYLVANIA, ASSIGNOR TO OSCAR C. FERRIS AND FREDERICK B. MILES, OF SAME PLACE.

## IMPROVEMENT IN WORK-HOLDING DEVICES.

Specification forming part of Letters Patent No. 146,064, dated December 30, 1873; application filed August 4, 1873.

*To all whom it may concern:*

Be it known that I, FRANCIS E. HAHN, of Philadelphia, Pennsylvania, have invented a Compound Retaining Attachment for Drilling and other Machines, of which the following is a specification:

The object of my invention is to provide drilling-machines, and other metal-working tools, with an attachment which can be readily adjusted for the support and retention of the different objects to be submitted to the action of the tool; and this object I attain by a block, A, fitted snugly, but so as to be turned freely, on a pin, B, which, in the present instance, forms a part of a swinging bracket, E, adapted to the column D of a drill-press, as shown in the perspective view, Figure 1, of the accompanying drawing, the sides of the block being provided with different appliances for supporting or retaining objects to be drilled, any of which appliances can, by simply turning the block, be brought to a position beneath the drill. One side of the block A is provided with a turn-table, *a*, which takes the place of the ordinary table of a drill-press. A second side is provided with the jaws *b b'* of a vise, one being fixed and the other being movable and controlled by a screw, in a manner too well known to need either description or illustration. A third side is provided with an adjustable slotted plate, *d*, to which a variety of objects may be conveniently bolted, and a fourth side has a fixed head-stock, *e*, and sliding head-stock *e'*, by and between the centers *f f'* of which centered spindles, and other objects which have been turned in a lathe, may be confined by a screw for controlling the sliding head-stock, in a manner which needs no explanation. The block A may be adjusted on the pin B, from or toward the column D, to any desired point, and secured after adjustment by a set-screw, *x*, passing through the block and entering one of the longitudinal grooves in the pin B, (see side view, Fig. 2,) there being as many of these grooves on the pin as there are sides to the block, and the grooves being so arranged, in respect to these sides, as to insure the proper position of whichever of the four re-

taining appliances may be uppermost when the end of the screw enters a groove.

In place of a screw, a key may be used for securing the block after adjustment.

When the invention is applied to a drilling-machine, I prefer to so attach the bracket E, of which the pin B forms a part, to the column or frame D, that it can be raised or lowered, or moved laterally, in the same manner as the table of an ordinary drilling-machine, as it facilitates the adjustment of the objects secured to the block in any desired position beneath the drill. When the vise attachment, for instance, is uppermost, and the object to be operated on is confined by and between the jaws, every facility for adjustment is afforded by the lateral turning of the bracket E and by the sliding of the block on the pin B.

It will be evident to those familiar with metal-working tools that my invention may be used to advantage in connection with milling-machines, shaping-machines, and other like tools.

Although I prefer, in most cases, a block, A, with four sides, and as many different appliances, in many instances a block with but two or three different retaining appliances would form a valuable adjunct to a drilling or other metal-working machine, and, in some instances, an adjustable block with more than four retaining or supporting appliances might be used.

It should be understood that I do not desire to restrict myself to an adjustable block with the special appliances herein described to the exclusion of others, for, in some cases, a block might have two vises differently constructed for different kinds of work, or a block may have slotted plates *d*, differing in character from that shown; in fact, the construction and style of the supporting and retaining appliances to be attached to the block will always depend upon the character of the work to be operated on by the machine to which the block has to be applied.

I claim as my invention—

1. The combination, in a drilling, milling, or other metal-working machine, of a vertically-adjustable bracket, E, its pin B, and the

block A, which admits of being adjusted longitudinally and turned laterally on the said pin, and which has two or more supporting or retaining appliances, all substantially as and for the purpose set forth.

2. The combination of the block A, having different appliances for receiving and retaining objects, the pin B, having as many grooves as there are different appliances on the block, and the set-screw *x*, or a key adapted to the

block and grooves, all as set forth, for the purpose specified.

In testimony whereof I have signed my name to this specification in the presence of two subscribing witnesses.

F. E. HAHN.

Witnesses:

WM. A. STEEL,

HUBERT HOWSON.